

# MJ45-T826GYGY-x-S118

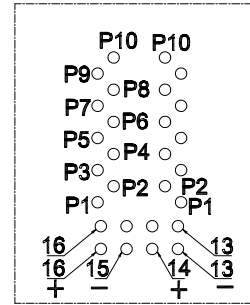

鍍層厚度:

Blank	: 1u"
1	: 3u"
2	: 15u"
3	: 30u"
5	: 6u"
6	: 50u"



DETAIL A  
SCALE 3:2

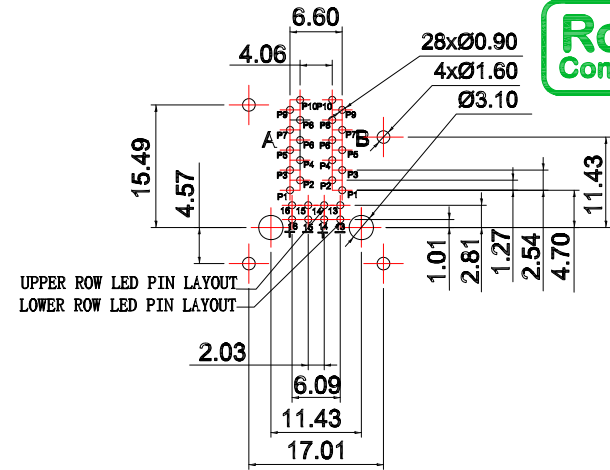

P.C.B LAYOUT

PARAMETER	SPECIFICATIONS
URNS RATIO	1:1±2%
INDUCTANCE(OCL)	350uH MIN@100kHz/100mV With 8mA DC Bias
INSERTION LOSS	-1.0dB MAX@0.3MHz-100MHz;
RETURN LOSS (Z out=100 OHM)	-18dB MIN@1MHz-30MHz; -18dB MIN@30MHz-60MHz; -12dB MIN@60MHz-80MHz; -10dB MIN@80MHz-100MHz;
CROSSTALK (ADJACENT CHANNELS)	-30dB MIN@1-100MHz;
COMMON MODE REJECTION RATIO	-30dB MIN@1-100MHz;
HI-POT	2250 VDC@60 SECONDS

LED SPECIFICATION			
STANDARD LED	WAVELENGTH	Forward Voltage	TYP
GREEN/YELLOW	670/690nm	2.8V/2.5V	2.1(2.2)

\*WITH A FORWARD CURRENT OF 20mA

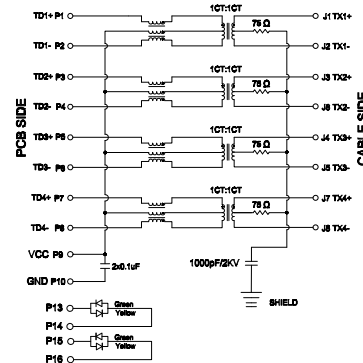
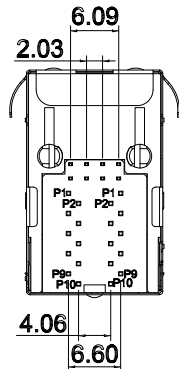
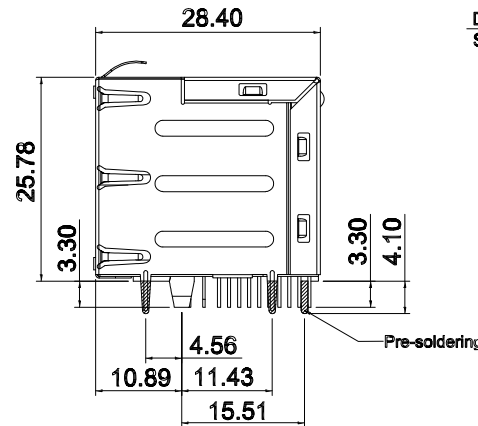
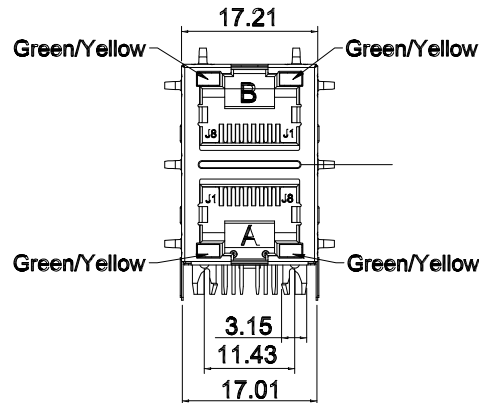

Schematic

## MATERIALS

- HOUSING: PA46(BLACK)
- CONTACT: PHOSPHOR BRONZE OVERALL DUCTILE NICKEL UNDERPLATE WITH SELECTED 6 MICROINCHES GOLD AT MATING INTERFACE
- SHIELD: STAINLESS.
- JACK CAVITY CONFORMS TO FCC RULES AND REGULATIONS PART 68 SUBPART F
- THE PART IS RECOMMENDED FOR WAVE SOLDERING PROCESS PEAK SOLDERING TEMPERATURE IS 260°C MAX,10 SECS MAX.
- OPERATING TEMPERATURE:-40°C TO +85°C.  
STORAGE TEMPERATURE:-40°C TO +85°C.

**CONTACT** 建倚科技股份有限公司  
CONTACT TECHNOLOGY CORP.

TOLERANCE UNLESS OTHERWISE STATED:

Up to 5 ±0.2  
Above 5 ~ 15 ±0.3  
Above 15 ~ 30 ±0.4  
Above 30 ~ 50 ±0.5  
Angle ±0.3°

3RD. ANGEL'S



UNITS MM

DRAWN BY:	DATE	MAT'L	TITLE	RJ45
Jack Lu	07/05/21	FINISH	MODLE	RJ45 2x1 Through Hole 10 100 1000 BASE-T WITH LED
CHECKED BY:	DATE	SCALE	DWG NO.	MJ45-T826GYGY-x-S118
Jacky Chen	07/05/21	1 : 1	PART NO.	MJ45-T826GYGY-x-S118
APPROVED BY:	DATE	SHEET NO.		SIZE A4
Tony Kao	07/05/21	2 of 1		VER R

ITEM NO.	DESCRIPTION	DRAWN	DATE
----------	-------------	-------	------